



TRS.2SSR

THREEAXIAL ANGULAR SENSOR



- Inclinator sensor based on a single CPU and a single 3D MEMS accelerometer
- Switch a relay with dry contacts on a set threshold value
- Implementable as a SLAVE in a CAN network
- Polyurethane resin case



TECHNICAL FEATURES

MASTER CODE	TRS.2SSR	
POWER SUPPLY	9-36 VDC / CURRENT CONSUMPTION 15 mA AT 24 VDC (stand-by)	
CAN BUS	1 PORT	2.0B COMPLIANT - (11, 29 BIT) - ISO 11898 - UP TO 1MBIT/S
CAN BUS PROTOCOLS	CAN OPEN (CIA DS410 DEVICE PROFILE FOR INCLINOMETER, WITH DS306 COMPLIANT EDS FILE)	
OUTPUT	RELAY SWITCH DRY CONTACT	
	MAX CURRENT	2 A
	OVER CURRENT PROTECTION	NO
	SHORT CIRCUIT PROTECTION	NO
TECHNOLOGY	3D MEMS ACCELEROMETER	
SAFETY	SINGLE CPU AND SINGLE SENSOR	
MEASURE OPTIONS	ANGLE	
	TILT	
LED	NR.1 STATUS LED	
CONNECTION PORT	WIRED, WITH 30 cm SINGLE CABLE LENGHT	
CASE	ENCAPSULATED IN PUR RESIN - SELF-EXTINGUISHING UL94 (V0)	
WORKING TEMPERATURE	-40°C +80°C	



(20/02/2026) - 1



TRS.2SSR

THREEAXIAL ANGULAR SENSOR

ELECTRONIC FEATURES

SLAVE USAGE	EDS FILE	
PROGRAMMING	FIRMWARE UPLOAD BY CAN BUS WITH ALOADER SOFTWARE TOOL	
CONFIGURING	THROUGH ALTILT CONFIG	
CPU	SINGLE 16 bit MICROCONTROLLER CORE	
SAMPLE TIME	LESS THAN 5 ms	
MEASURING RANGE	TILT	0 - 360°
	ANGLE	-180°+180°
ACCURACY	TILT	0,01°
	ANGLE	0,1°

STANDARDS

ELECTROMAGNETIC EMISSIONS	EN 61000-6-4// EN 55011 (RF RADIATE)
ELECTROMAGNETIC IMMUNITY	EN 61000-6-2// EN 61000-4-2/3/4/6
IP	BOX: IP67
MTTFd	216,03 YEARS CALCULATED ACCORDING TO THE IEC61709 (SIEMENS SN29500), WITH ENVIRONMENTAL FACTORS 3K7 (IEC60721)
PERFORMANCE AND SAFETY INTEGRITY LEVEL	PLc – SIL1 (SINGLE CHANNEL INTERNAL SCHEME)

IN ACCORDANCE WITH THE EN50498 THE DEVICE MEETS THE TECHNICAL SPECIFIC REQUIREMENTS OF 2004-104 DIRECTIVE (AUTOMOTIVE). THE DEVICE IS EMC 2004/108 COMPLIANT.

SIZE (mm)

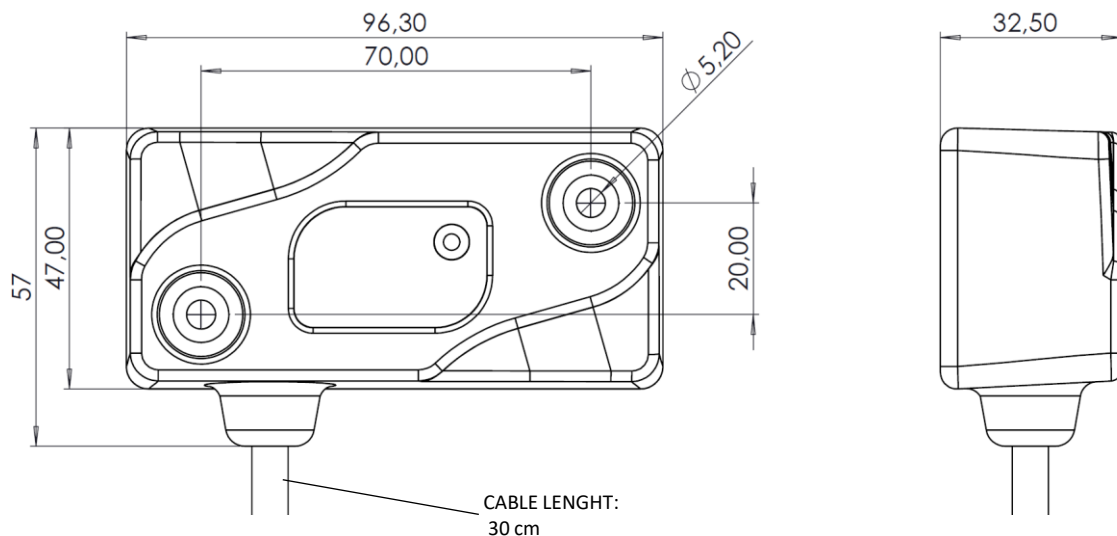



TRS.2SSR

THREEAXIAL ANGULAR SENSOR

OUTPUT FEATURES

CONFIGURATION A

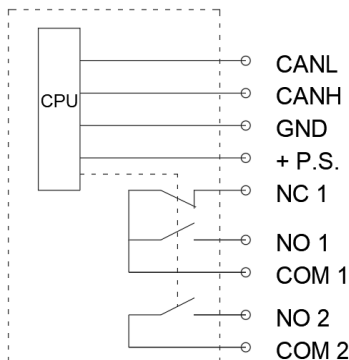

OUTPUT SWITCH RELAY WITH DRY CONTACT
No.2 NO CONTACT
No.1 NC CONTACT

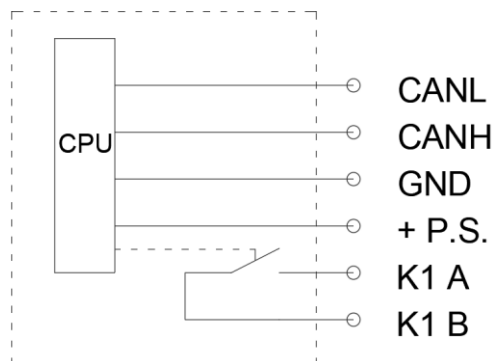

CONFIGURATION B

OUTPUT SWITCH RELAY WITH DRY CONTACT
No.1 NO CONTACT



CONNECTOR	PIN	WIRE COLOR	DESCRIPRION
CONNECTOR 1 AMP SUPERSEAL 4 PIN FPM 	1	BN	POSITIVE P.S.
	2	YE	CAN L
	3	WH	GND POWER SUPPLY
	4	RD	CAN H
CONNECTOR 2 AMP SUPERSEAL 6 PIN MPF 	1	VT	ZERO IN
	2	TQ	NC SWITCH 1
	3	BK	NO SWITCH 1
	4	GY	COM SWITCH 1
	5	GN	NO SWITCH 2
	6	PK	COM SWITCH 2

CONNECTOR	PIN	WIRE COLOR	DESCRIPRION
CONNECTOR 1 AMP SUPERSEAL 6 PIN FPM 	1	BN	POSITIVE P.S.
	2	YE	CAN L
	3	WH	GND POWER SUPPLY
	4	RD	CAN H
	5	VT	NO SWITCH IN (K1A)
	6	TQ	NO SWITCH OUT (K1B)

MEASURE OPTIONS

S01

TRASDUCER WITH ANGLE MEASUREMENT MODE ONLY ON Z AXIS
(ANGLE MEASUREMENT)



S04

TRASDUCER WITH ANGLE MEASUREMENT MODE ON X & Y AXIS
(TILT MEASUREMENT)





NOTE